

The increased concentration of the solution gives an increase in molecular weight.

The data obtained differ greatly from those obtained by analyses and the difference between the values of each one of the above acids is too considerable to admit assigning a value to any one of these determinations by themselves. In comparison with each other, however, they show that the molecular weight of the second acid is much greater (almost double the first acid). Taking into consideration that these two acids are formed under different conditions in temperature and were not found together in any proportions in the same experiment and the difference in crystalline form and molecular weight, it will be necessary to admit that the second of these acids is a condensation product of the first and its formula will be according to the formation:

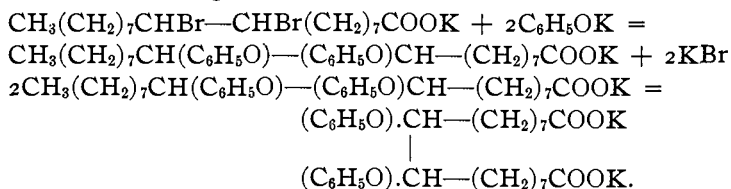

Under the same conditions, but lower temperature, two other acids are formed:

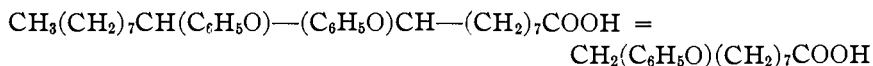

and

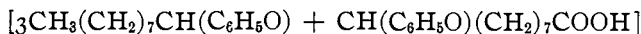

The investigation is being continued.

URBANA, ILL.

[CONTRIBUTION FROM THE DEPARTMENT OF CHEMISTRY, UNIVERSITY OF CINCINNATI.]

## INTERPRETATIONS OF SOME STEREOCHEMICAL PROBLEMS IN TERMS OF THE ELECTRONIC CONCEPTION OF POSITIVE AND NEGATIVE VALENCES.

### II. HALOGEN SUBSTITUTION IN THE BENZENE NUCLEUS AND IN THE SIDE CHAIN.

BY HARRY SHIPLEY FRY.

Received March 16, 1914.

The present paper, the second of a series<sup>1</sup> relating particularly to the interpretations of some stereochemical problems, is an extension of the principles which have been presented, applied, and discussed in previous papers.<sup>2</sup> The subject matter of this paper, halogen substitution in the

<sup>1</sup> Fry, *THIS JOURNAL*, 36, 248 (1914).

<sup>2</sup> Some of the earlier papers dealt with problems relating to chemical constitution from the standpoint of electronic formulas and chemical properties. Fry, *THIS*

benzene nucleus and in the side chain, may be limited appropriately to a discussion and an interpretation of the action of the halogens, chlorine and bromine, upon toluene. There are two very evident reasons for this: (1) Toluene is the simplest derivative of benzene which may be regarded as possessing a side chain, or, perhaps more correctly, a radical, the hydrogen atoms of which are comparable in their chemical behavior to the hydrogen atoms of side chains containing more than one carbon atom. (2) Practically all of the research relating to the problem of substitution in the benzene nucleus and in the side chain has been confined to the action, under various conditions, of chlorine and bromine upon toluene.

A comprehensive idea of the nature and extent of the work upon this subject has been presented by Bancroft from the standpoint of "halogen-carriers" and the electrochemistry of light.<sup>1</sup> The general conclusions, briefly indicated, are as follows: Toluene undergoes substitution either in the nucleus or in the side chain according to the conditions. Schramm<sup>2</sup> found that chlorine or bromine substitute the hydrogen atoms of the side chain at 0° and at higher temperatures *in the sunlight*. In diffused daylight and in the dark a mixture of ortho and para chloro- and bromotoluene results, and a like effect is produced among the higher homologues. Cannizzaro<sup>3</sup> observed that side-chain substitution took place in the dark at the boiling point of toluene. On the other hand, nucleus substitution is induced by the usual carriers such as ferric chloride, molybdenum and antimony pentachloride, iodine chloride, pyridine, and the aluminium-mercury couple. The most recent and noteworthy contribution is the work of Cohen, Dawson, Blockey, and Woodmansey,<sup>4</sup> who found that, at the boiling point of toluene, moist chlorine in the dark produces nuclear substitution to the extent of nearly 90%, whereas in

JOURNAL, 30, 34 (1908); *Z. physik. Chem.*, 76, 385 (1911); THIS JOURNAL, 34, 664 (1912); *Ibid.*, 36, 262 (1914). Other papers presented relationships between the chemical constitution (electronic and dynamic formulas) and the absorption spectra of benzene (Fry, *Z. physik. Chem.*, 76, 398 (1911)), of naphthalene (*Ibid.*, 76, 591 (1911)), and of chloro-, bromo-, and iodobenzene (*Ibid.*, 82, 665 (1913)). A theory on fluorescence, with special reference to anthracene and phenanthrene, has also been developed (Fry, *Z. physik. Chem.*, 80, 29 (1912)).

The recent papers of W. A. Noyes (THIS JOURNAL, 35, 767 (1913)); L. W. Jones (*Amer. Chem. J.*, 50, 414 (1913)); Nelson and Falk (THIS JOURNAL, 36, 272 (1914)), and Stieglitz (*Ibid.*, 36, 272 (1914)), present a variety of interesting applications of the electronic conception of positive and negative valences, and also embody references to their other papers upon this subject.

<sup>1</sup> *J. Phys. Chem.*, 12, 417 (1908). See also Cohen and others, *J. Chem. Soc.*, 97, 1623 (1910).

<sup>2</sup> *Ber.*, 18, 350, 606, 1272 (1885); *Ibid.*, 19, 212 (1886); *Bull. Acad. Scient. Cracow*, 1898, p. 61.

<sup>3</sup> *Compt. rend.*, 41, 517 (1855).

<sup>4</sup> *Loc. cit.*

the light dry chlorine increases side-chain substitution, yielding on the average about 94% of benzyl chloride. Furthermore, they make this statement: "In so far as the resultant effects are concerned, the action of moisture is opposed to that of light, for this increases the rate of side-chain substitution, and the former accelerates the rate of nuclear substitution."

Various explanations have been proposed to account for these remarkable phenomena. Especially noteworthy are those of Bruner,<sup>1</sup> Bancroft,<sup>2</sup> and Holleman.<sup>3</sup> The fundamental features of these explanations should be noted briefly since they are to be reconsidered from the electronic standpoint of valence.

Bruner maintains that side-chain substitution is due to molecular halogen, while nucleus substitution is effected by halogen atoms or ions which result from the dissociation of the halogen molecules. The velocity measurements of Bruner and Dluska favor this hypothesis, since both side-chain and nucleus substitution processes apparently take place according to the requirements of the equation for a unimolecular change, if the concentration of the bromine is small. For higher concentrations of bromine the values obtained for the unimolecular constant decrease as the reaction proceeds. This is attributed to the removal of the active bromine from the solution by the formation of a perbromide, (HBr<sub>3</sub>).

Bruner's idea that nucleus substitution is due to ionic bromine is also maintained by Bancroft, who further assumes that nuclear substitution occurs when *negative* bromine ions are present in excess of the positive bromine ions. This condition is brought about presumably by the partial combination of positive bromine ions with molecular bromine to form complex positive ions, thus:

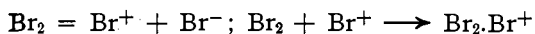

On the other hand, Bancroft maintains that side-chain substitution takes place under conditions which tend to yield a preponderance of positive bromine ions.

Holleman assumes that side-chain substitution is due to molecular bromine, while nucleus substitution is brought about by a perbromide, HBr<sub>n</sub>. The formation of these polyhalogen compounds is actually favored by low temperature and increasing concentration of solution, and these are the conditions which also favor nucleus substitution.

Notwithstanding the various explanations that have been proposed to account for the remarkable phenomena encountered in nucleus and in

<sup>1</sup> *Z. physik. Chem.*, **41**, 513 (1902); *Bull. Acad. Scient. Cracow*, **1907**, p. 691; *Ibid.*, **1910**, pp. 516 and 560.

<sup>2</sup> *Loc. cit.*

<sup>3</sup> *Rec. trav. chim.*, **27**, 435 (1908).

side-chain substitution, Cohen frankly states<sup>1</sup> "*it must be confessed that nothing definite is known about the mechanism of the process.*" In this connection, it may be of interest to recall a statement made by Brown and Gibson<sup>2</sup> when they formulated a rule for determining whether a given benzene mono-derivative shall give chiefly a meta-di-derivative or a mixture of ortho and para di-derivatives. They stated that their rule is not a law, because "it has no visible relation to any *mechanism* by which substitution is carried out in one way, rather than in another way;" but, since they found it capable of most rigorous application, they concluded that "it must be related in some way to a law, and may be of use in guiding us to the cause of the formation of meta compounds in some cases, and of ortho and para in others." Now the application of the electronic conception of positive and negative valences to the constituent atoms of the benzene molecule and to the principles of the Brown and Gibson rule not only rendered possible an interpretation of the rule but also indicated a *mechanism* according to which substitution must take place in one way rather than in another way.<sup>3</sup> This was a consequence of the evidence, both theoretical and experimental, that in benzene the hydrogen atoms in positions 1, 3, and 5 are negative, while the hydrogen atoms in positions 2, 4, and 6 (relatively speaking) are positive. Accordingly, when substituents are of the same sign or polarity they occupy positions which are meta to each other, but if two substituents are of opposite sign or polarity they will occupy positions either ortho or para to each other. This general principle also rendered possible interpretations of the anomalous behavior of various substituted derivatives of benzene.<sup>4</sup> Therefore, it is hoped that the extension of these principles and the electronic conception of valence to the *phenomena* and *conditions* of nucleus and side-chain substitution may afford not only an explanation of the phenomena but also indicate a possible and a probable mechanism of the process.

#### Nucleus Substitution in Toluene.

Any interpretation of the action of the halogens upon toluene, under the various conditions just noted, must take into account the following facts: (1) The presence of water (moisture), (2) low temperatures, (3) the absence of sunlight (subdued daylight or darkness), and (4) the presence of halogen carriers all favor nucleus substitution, with the consequent formation of *o*- and *p*-chloro- or bromotoluenes. On the other hand, the elimination of water, higher temperatures, and sunlight are the conditions which favor side-chain substitution.

Omitting, temporarily, the discussion of the action of halogen carriers,

<sup>1</sup> "Organic Chemistry for Advanced Students," 2, 397 (1913).

<sup>2</sup> *J. Chem. Soc.*, 61, 367 (1892).

<sup>3</sup> Fry, *Loc. cit.*, THIS JOURNAL and *Z. physik. Chem.*

<sup>4</sup> Fry, *Loc. cit.*

it is quite important to note that the conditions (1), (2), and (3) which favor substitution in the nucleus are the very conditions which promote the formation, and conserve the stability of, hypochlorous and hypobromous acids (HOX) in which the halogen (X) functions positively. On the other hand, the conditions which favor side-chain substitution, namely heat, light and the absence of water, are those which render hypochlorous and hypobromous acids unstable and promote their action as oxidizing agents. These facts are now to be interpreted as warranting the assumption that substitution in the nucleus in the presence of water (even in minutest traces) is favored by the intermediate formation of hypochlorous or hypobromous acids which on interaction with toluene effect *nucleus substitution of positive halogen*.

It should be recalled, in this connection, that substituted halogen may function sometimes positively, sometimes negatively. For instance in *o*- and *p*-chloro- or bromonitrobenzenes the halogen atoms are negative, since they are exchanged for negative hydroxyl in double decomposition reactions with aqueous potassium hydroxide, ( $K^+OH^-$ ). On the other hand, the halogen atoms in the *m*-nitro compounds are regarded as positive for the following reasons: First, the halogen atom is not exchangeable for negative hydroxyl. Second, it is in the meta position to the positive nitro radical, and, according to the electronic formula of benzene, those substituents which are meta to each other are of the same sign or polarity. Third, the substitution of halogen in the nucleus is facilitated if the reagents are not anhydrous. This indicates the possibility of the intermediate formation of the hydroxy halogen acid (HO.X) in which the halogen (X) is positive. Accordingly, the electronic equations for the formation of *m*-chloro- and *m*-bromonitrobenzenes are represented as follows:

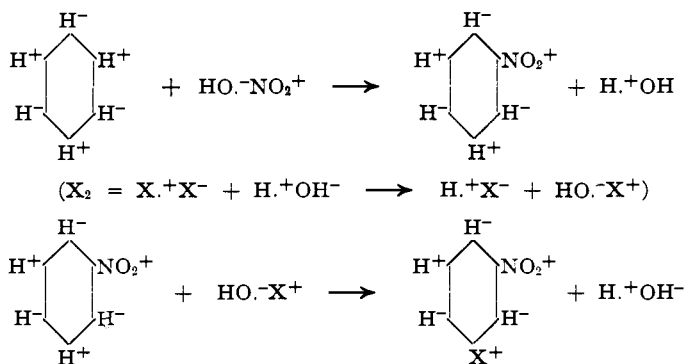

The substitution of positive halogen in toluene proceeds in the same way, but here the halogen assumes the ortho or the para position to the negative methyl radical as follows:

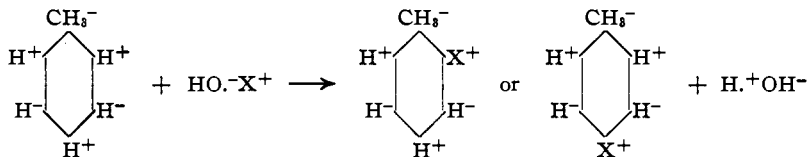

Further evidence of the positive character of the nucleus substituted halogen of toluene is shown by an application of the electronic conception of valence to the Brown and Gibson rule<sup>1</sup> from which standpoint toluene is a derivative of  $\text{H} \cdot \text{CH}_3^-$  and not  $\text{HO} \cdot \text{CH}_3^+$ . Hence substituents ortho or para to the negative methyl radical must be positive. Moreover the substituted halogen atoms are not directly exchangeable for negative hydroxyl and hence are regarded as positive.

The above conclusions are directly opposed to the assumption of Bancroft that nucleus substitution is due to negative halogen. The work of Cohen, showing that moisture increases both the rate and extent of nucleus substitution, also contradicts Bancroft's assumption, if we admit the interaction of the intermediately produced hydroxy-halogen acid ( $\text{HO} \cdot \text{X}^+$ ) upon toluene according to the above electronic formulas and equations.

Since water increases both the rate and extent of nucleus substitution, is it not reasonable to regard water as a halogen carrier? This point of view may throw some light upon the action of halogen carriers in general in effecting nucleus substitution. For instance, pyridine and iodine chloride may be compared to water in that each contains an unsaturated atom which renders possible the formation of addition compounds as follows:

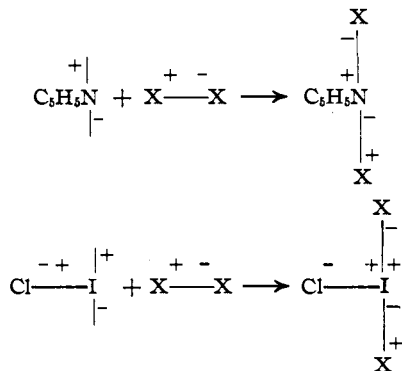

Either of these halogen addition-compounds may dissociate in two ways. Consider the pyridine compound:

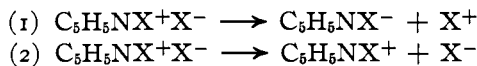

<sup>1</sup> *Loc. cit.*; also Fry, *Z. physiol. Chem.*, 76, 385 (1911).

The previously presented evidence favors dissociation according to equation (1) since it would account for the nucleus substitution of positive halogen. Further evidence is afforded from the standpoint of a comparison of the relative stability of the nitrogen halogen linkings in the halogen addition-compounds. The pyridine halogen compound shows the linkings (N — + X) and (N + — X). The former linking is presumably the least stable and therefore more likely to undergo dissociation, yielding positive halogen. This assumption is warranted by the extreme instability of compounds embodying this linking. For example, W. A. Noyes<sup>1</sup> first showed that the halogen atoms in nitrogen trichloride were positive and bound to negative nitrogen valences. This compound is extremely unstable. The substituted nitrogen halides<sup>2</sup> also embody the linking (N — + X) and are likewise very unstable, exchanging the positive halogen atom for positive hydrogen of the nucleus thereby developing a more stable linking (N — + H) thus:

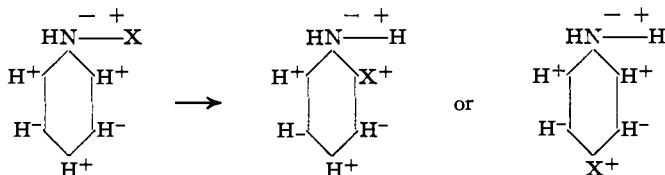

On the other hand the compounds nitrosyl chloride and bromide of the formula  $\text{O} \begin{array}{c} - + \\ \equiv \\ - + \end{array} \text{N} \text{---} \text{X}$  embody the linking (N + — X) and are very stable in comparison with the previously noted compounds containing the N (— + X) linking.<sup>3</sup>

Considering the other typical halogen carrier,  $\text{Cl} \text{---} \text{I} \begin{array}{c} \text{X} \\ | \\ - + + \\ | \\ - + \\ | \\ \text{X} \end{array}$ , it appears

<sup>1</sup> THIS JOURNAL, 23, 460 (1901).

<sup>2</sup> Fry, *Ibid.*, 34, 667 (1912).

<sup>3</sup> These conceptions are not to be confused with the previously presented idea (Fry, *Z. physik. Chem.*, 76, 387 (1911)) that the polarity of a linking may be reversed through the transposition of electrons, thus giving rise to the conception of electronic isomerism and the possibility of tautomerism of two (or more) electromers,  $\text{R} \text{---} \text{X} \rightleftharpoons \text{R} \text{---} \text{X}$ , the existence of either electromer depending upon certain physical conditions. These conceptions were subsequently discussed by Bray and Branch (THIS JOURNAL, 35, 1445 (1913)) from the standpoint of valence and tautomerism. A recent paper by L. W. Jones develops this conception from the standpoint of intramolecular oxidation and reduction, which renders possible the interpretation of the reactions of numerous nitrogen compounds (*Amer. Chem. J.*, 50, 414 (1913)).

that the linking (I + — X) is more stable than (I — + X) This is substantiated by the fact that iodine in iodine chloride and in iodine bromide is positive as evidenced by its interaction with potassium hydroxide, yielding potassium hypoiodite in which the iodine is positive:

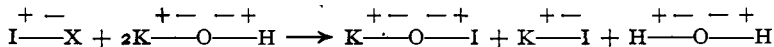

Accordingly, the halogen addition compound would maintain the more stable linking, I + — X, and yield the positive halogen ion as follows:

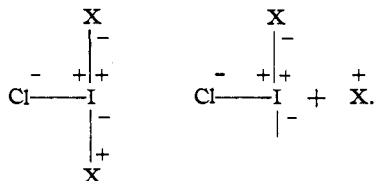

From the above points of view the following mechanism, or cycle of changes, will illustrate the part played by the halogen carrier in effecting the nucleus substitution of positive halogen in toluene. "R" represents any halogen carrier such as water, pyridine, iodine chloride, phosphorus-antimony- and molybdenum-trihalides, or any other compound containing an atom which in uniting with chlorine or bromine X<sub>2</sub> increases its valence from (n) to (n + 2) as follows:

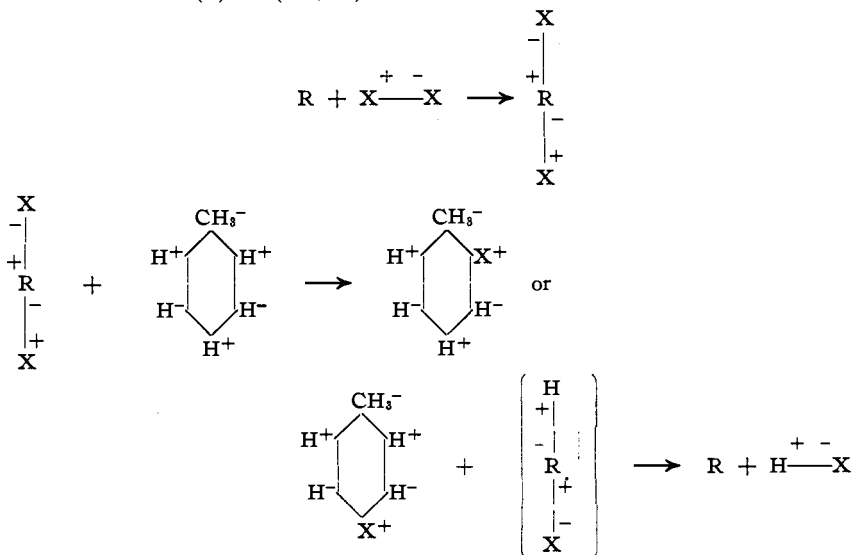

It should be observed that the halogen acid eliminated during the course of the substitution is of the type  $\overset{+}{\text{H}}-\overset{-}{\text{X}}$ , and not  $\overset{-}{\text{H}}-\overset{+}{\text{X}}$ , the latter electromer never having been identified. If neither oxidation



nor reduction has occurred during nucleus substitution then the elimination of  $\overset{+}{\text{H}}-\overset{-}{\text{X}}$  is conclusive evidence that the substituted halogen atom is positive, the reaction having proceeded as indicated above. Halogen carriers of other types may function similarly, *i. e.*, substitute positive halogen and eliminate  $\overset{+}{\text{H}}-\overset{-}{\text{X}}$ . A further discussion of the mechanism of the action of halogen carriers is reserved for a subsequent paper.<sup>1</sup>

### Side-Chain Substitution.

In what respects does side-chain substitution differ from nucleus substitution? It has just been shown that nucleus substitution of toluene yields ortho and para halogen toluenes in which the halogen is positive, but when side-chain substitution takes place experimental evidence shows that the substituted halogen atoms are negative. This evidence is as follows:

Benzyl chloride, benzal chloride, and benzotrichloride (or bromides) are readily hydrolyzed by water or by potassium hydroxide, yielding, respectively, benzyl alcohol, benzaldehyde, and benzoic acids. In each of these hydrolyses, chlorine (or bromine) is replaced by negative hydroxyl, which signifies that the substituted halogen atoms of the side chain are negative. The reaction for the hydrolysis of benzyl chloride, or bromide, is typical and may be represented by the following electronic equation:

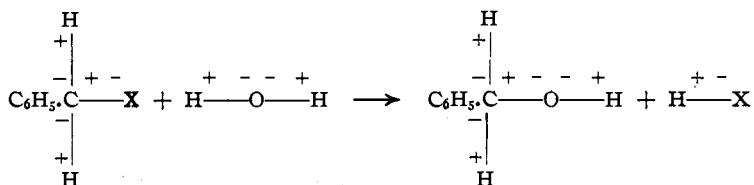

This reaction may be reversed by the action of hydrogen halide ( $\overset{+}{\text{H}}-\overset{-}{\text{X}}$ ) which converts benzyl alcohol into benzyl halide. This also establishes the fact that halogen atoms substituted in the side chain are negative. An interpretation of these facts must correlate the electronic conception of positive and negative valences with the conditions under which side-chain substitution takes place.

The most significant feature to be noted is that in nucleus substitution the positive hydrogen atoms of toluene are replaced by positive halogen atoms, which change involves neither oxidation nor reduction. But in side-chain substitution, positive hydrogen atoms are replaced by negative halogen atoms. In other words, side-chain substitution involves oxida-

<sup>1</sup> Any halide functioning as a halogen carrier may conform to the above scheme, since its halogen atoms may be unsaturated and hence combine with other halogen atoms just as the iodine atom in iodine chloride lends itself to the formation of iodine trichloride.

tion and reduction: the carbon-hydrogen linking ( $C - + H$ ) is changed to a carbon-halogen linking ( $C + - X$ ). The negative valence of carbon is oxidized to a positive valence and this change could not occur unless the substituting agent is reduced. Now the substituting agent (molecular halogen,  $X_2$ ) must undergo dissociation into positive and negative halogen atoms, and the negative halogen naturally combines with the positive hydrogen of the side chain to form hydrogen halide,  $H - X$ . This necessitates the conclusion that *the remaining positive halogen atom (nascent halogen)<sup>1</sup> acts as the oxidizing agent which converts the negative valence of carbon to a positive valence.* The positive halogen atom is thereby reduced to a negative halogen atom which is then bound by the positive valence of carbon. The changes thus involved in side-chain substitution may be represented as follows:

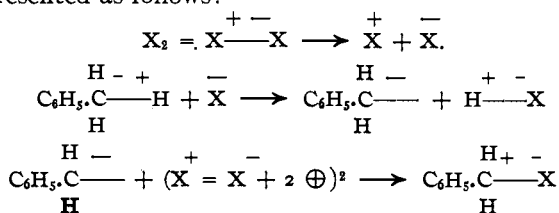

The remaining hydrogen atoms of the side chain undergo substitution in precisely the same manner.

Having indicated a mechanism which accounts for the substitution of negative halogen in the side chain and thereby involves an oxidation of negative valences of carbon to positive valences, it is now desirable to account for the fact that nucleus substitution does not involve oxidation while side-chain substitution does.

It has been observed that the conditions which promote nucleus substitution (omitting halogen carriers which have been considered) are low temperatures and the absence of sunlight. These are the conditions which promote the formation and conserve the stability of hypochlorous and hypobromous acids, that is, prevent their decomposition as oxidizing agents. On the other hand the chief conditions promoting side-chain substitution (heat and sunlight) are the very factors which render these hydroxy-halogen acids unstable and effect their decomposition as oxidizing agents. Let us now inquire into the most significant feature of these changes. If hypochlorous or hypobromous acids are heated or exposed

<sup>1</sup> An interpretation, from the electronic standpoint, of the nascent state and its relation to oxidation and reduction phenomena has been given in a previous paper (Fry, *THIS JOURNAL*, 36, 262 (1914)).

<sup>2</sup> Positive halogen atoms act as oxidizing agents since they tend to become negative by acquisition of electrons. In terms of the atomistic conception of electricity, the acquisition of negative electrons is equivalent to the liberation of the so-called "positive electrons" which convert negative valences into positive valences.

to the action of sunlight, oxygen is evolved and hydrogen chloride or bromide is formed ( $2\text{HOX} \rightarrow 2\text{HX} + \text{O}_2$ ). The halogen in HOX is positive; in HX it is negative. Hence it follows that heat, and especially the photochemical action of light, effect the conversion of positive halogen to negative halogen, thus,  $\text{X}^+ \rightarrow \text{X}^- + 2\oplus$ . This is the oxidation process upon which the elimination of oxygen from HOX depends.<sup>1</sup> Now the substitution of halogen in the side chain, as described above, is also an oxidation process, since it likewise involves the essential change,  $\text{X}^+ \rightarrow \text{X}^- + 2\oplus$ , induced either by heat or by photochemical action. Thus the conditions which favor and promote side-chain substitution are correlated with the fact that positive hydrogen atoms of the side chain are substituted by negative halogen atoms, which involves the reduction of positive halogen to negative halogen, and the consequent oxidation of negative valences of carbon to positive valences which bind the negative halogen atoms.<sup>2</sup>

In this paper some fundamental distinctions between nucleus and side-chain substitution have been developed and interpreted in terms of positive and negative valences. A common occurrence, however, should not be overlooked, namely, that in most substitution reactions it is practically impossible to so limit and regulate the conditions that the sole reaction taking place will be either nucleus substitution or side-chain

<sup>1</sup> Electronic equations for this change may be indicated in two ways: The first has been described in detail (Fry, THIS JOURNAL, 36, 267 (1914)). The second is from the standpoint of intramolecular oxidation and reduction (L. W. Jones, *Loc. cit.*) and may be represented as follows:

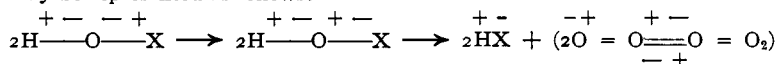

Either way of interpreting the change involves the reduction of positive halogen (an active or nascent form of halogen) to negative halogen and the consequent oxidation of negative valences of oxygen to positive valences.

<sup>2</sup> In this connection it may be of interest to note and to correlate another of many reactions in which light changes negative valences of carbon to positive valences. Euler and Ryd (*Biochem. Z.*, 97, 106) have shown that lactic acid under the influence of ultraviolet rays evolves carbon dioxide. The electronic interpretation depends upon the fact that lactic acid readily yields aldehyde and formic acid as follows:

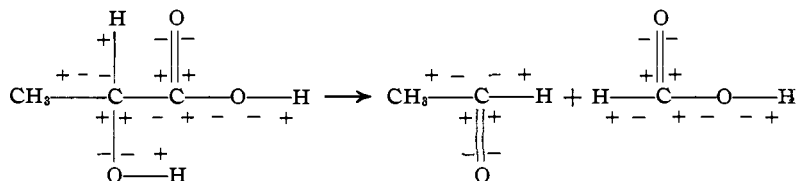

Now in order that formic acid, in which three of the carbon valences are positive and one is negative, may yield carbon dioxide, in which the four valences of carbon are positive, the one negative valence of carbon in formic acid must be oxidized to a positive valence. This change takes place when formic acid is catalytically or photochemically

substitution. In other words, the formation of ortho and para halogen toluenes, in which the halogen atoms are positive, and the introduction of negative halogen into the side chain, may proceed as simultaneous independent chemical changes. As previously noted the former process does not involve oxidation and reduction while the latter does. These facts are readily correlated with another general property characteristic of benzene on the one hand, and characteristic of aliphatic hydrocarbons (comparable to side chains) on the other hand. *Benzene resists oxidation while the aliphatic hydrocarbons and the side chains are generally more susceptible to oxidation.*

Finally, it is not impossible to conceive that, under certain conditions, which are not as yet determined and interpreted, a positive hydrogen atom of the benzene nucleus may be replaced by a negative halogen atom (or *vice versa*) which is characteristic of side-chain substitution, involving oxidation and reduction. Such a condition, however, does not invalidate the interpretations presented in this paper which are correlated with the experimental facts, the conditions of substitution, and the chemical properties of ortho and para halogen toluenes, and the side-chain substitution products.

In concluding, the relations between the interpretations given in this paper and the substitution hypotheses of Bruner, Bancroft, and Holleman should be reconsidered briefly.

Bruner's idea that nucleus substitution is due to halogen atoms, while side-chain substitution is due to molecules, thus,

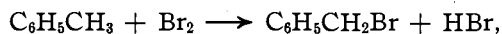
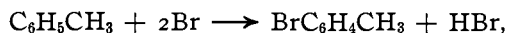

fails to take into account the fact that nucleus substitution (former equation) does not involve oxidation and reduction while side-chain substitution (latter equation) does.

Bancroft's assumption that nucleus substitution is due to negative halogen atoms is not in agreement with the evidence, both theoretical and experimental, that the ortho and para substituted halogen atoms of toluene are positive. His other assumption that the halogen substituted in the side chain is positive is also contradicted by the fact that the halogen decomposed, yielding carbon dioxide and hydrogen according to the following electronic equation:

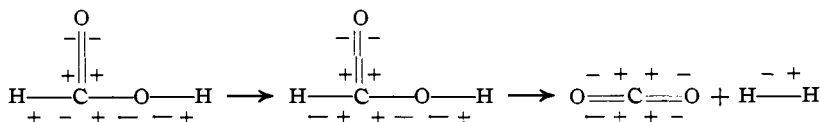

A further discussion of photochemical changes from this standpoint is reserved for a subsequent paper.

atoms in benzyl chloride, benzal chloride, and benzotrichloride (or bromides) are negative, since they are readily exchanged (without oxidation or reduction) for negative hydroxyl. It is true, however, that positive halogen atoms are the active substituting agents in side-chain substitution, but only by virtue of their oxidizing action and consequent reduction to negative halogen (photochemical action) as previously described.

Finally, Holleman has stated<sup>1</sup> "Il est démontré, que l'hypothèse, suivant laquelle le noyau est attaqué par des molécules  $\text{HBr}_n$ , tandis que la chaîne latérale l'est par les molécules de brome, a quelque vraisemblance; cependant un nombre de difficultés devoit encore être levées, avant qu'elle puisse servir à expliquer les phénomènes observés." The very plausible interpretation of the nucleus bromination of toluene through the action of the intermediately formed  $\text{HBr}_n$  may be readily correlated with the interpretation of nucleus substitution and the action of halogen carriers' as presented in this paper, provided  $\text{HBr}_n$  be regarded as

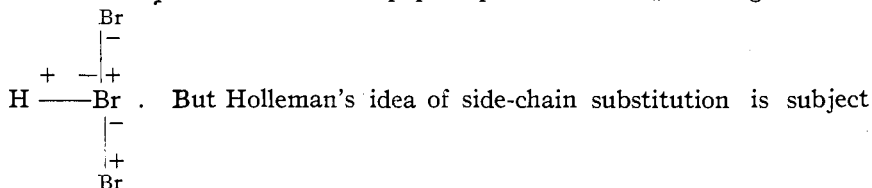

to the criticism that it also fails to recognize the side-chain substitution process as an oxidation and reduction phenomenon depending upon the reaction,  $\text{X}^+ \rightarrow \text{X}^- + 2\oplus$ , previously considered.

CINCINNATI, OHIO.

[CONTRIBUTION FROM THE HARRIMAN RESEARCH LABORATORY, ROOSEVELT HOSPITAL, NEW YORK.]

## STUDIES ON ENZYME ACTION. X. THE LIPOLYTIC PROPERTIES OF HUMAN DUODENAL CONTENTS.

By K. GEORGE FALK.

Received February 27, 1914.

The enzymes of the digestive tract play an essential part in the changes which foodstuffs must undergo before they can be utilized in the animal body. Within recent years it has become possible to remove the contents of the upper part of the intestinal tract of human beings directly and to study their properties. Much valuable information with regard to the enzymes present has already been obtained in this way. The results to be described in this paper deal with the lipolytic properties of duodenal contents obtained under varying conditions and tested in different ways. It is believed that a detailed study of the behavior of one enzyme may at the present time be more useful than the routine examination for the ordinary digestive enzymes.

<sup>1</sup> *Loc. cit.*